

THIS DRAWING IS UNPUBLISHED. RELEASED FOR PUBLICATION, 19 .
 © COPYRIGHT 19 BY AMP INCORPORATED. ALL INTERNATIONAL RIGHTS RESERVED.

LOC	DIST	P	F	ZONE	LTR	REVISIONS	DATE	APPD
AF	50					0 DRAWN PER 0266-94	5/26/94	JR/PD

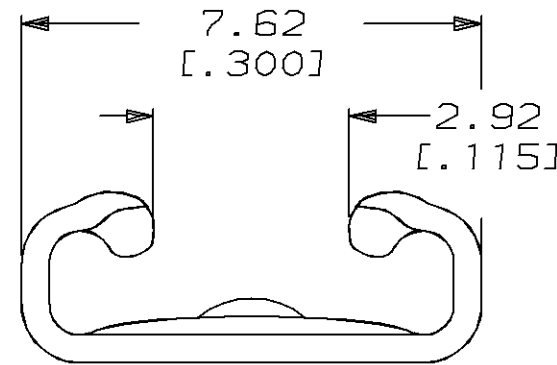
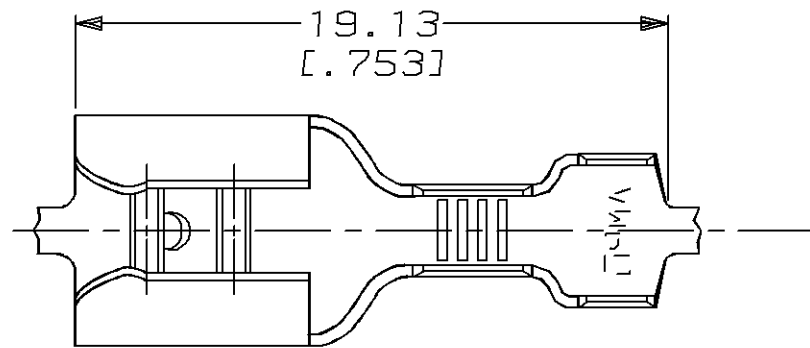

VIEW A-A
SCALE 8:1

- 1 CONTINUOUS STRIP ON REELS.
- 2 TIN PLATE 0.002032 [0.000080] MIN THK.

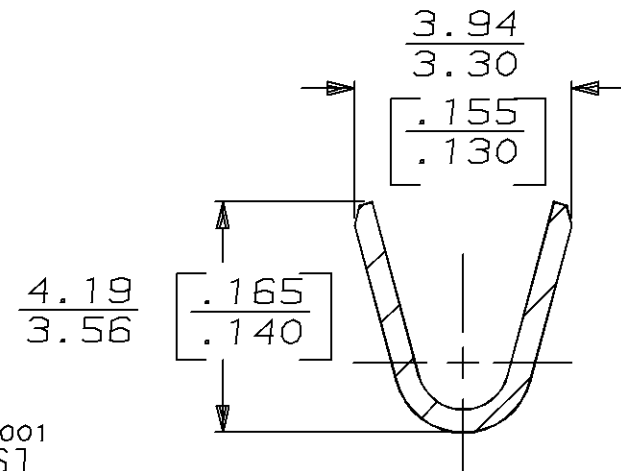
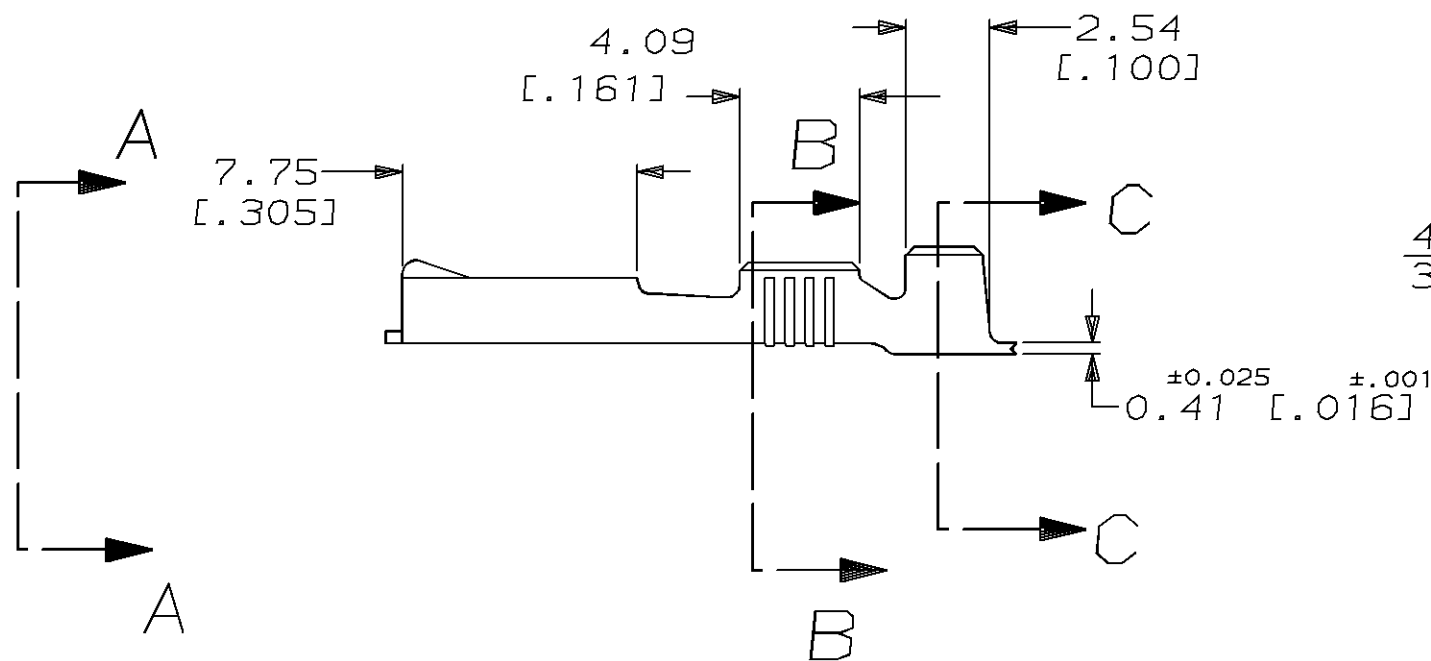

SECTION B-B
SCALE 8:1

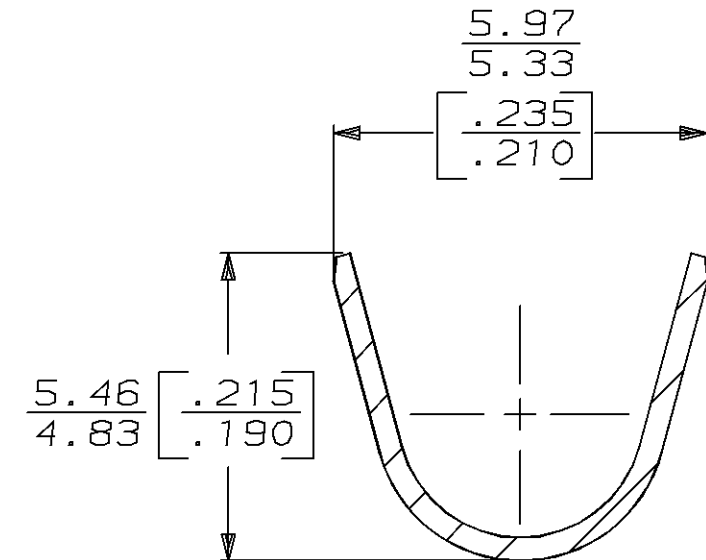

SECTION C-C
SCALE 8:1

3.05-4.32 DIA [.120-.170] DIA	[#18-#14] AWG	0.81 [0.032]	TIN Δ	60713-2
INSULATION RANGE	WIRE SIZE	MATING TAB THK ±0.025 [0.001]	-	60713-1
DO NOT SCALE PRINT. UNLESS SPECIFIED DIMENSIONS IN mm [INCHES] TOLERANCES ON: 2 PLC DEC ± 0.25 [0.010] 3 PLC DEC ± - ANGLES ± -	DR 5/26/94 JR RUTH CHK 5/26/94 MS FEHER APPD 5/26/94 P DESANTIS APPD 5/26/94 R REINER PRODUCT SPEC -	AMP AMP Incorporated Harrisburg, PA 17105-3608		
MATERIAL H04 BRASS	FINISH SEE TABLE	NAME RECEPTACLE, FASTON, 6.35 [.250] SERIES		
		SIZE B	CAGE CODE 00779	DRAWING NO C-60713
		SCALE 4:1	SHEET 1 OF 1	

THIS DRAWING IS A CONTROLLED DOCUMENT FOR AMP INCORPORATED. IT IS SUBJECT TO CHANGE AND THE CONTROLLING ENGINEERING ORGANIZATION SHOULD BE CONTACTED FOR THE LATEST REVISION.